



Building New-Generation Metropolitan Area Networks



Overview

Bandwidth growth has been explosive in the LAN propelled by the availability and deployment of Gigabit Ethernet.

WAN bandwidth has also exploded, fueled by the 300% annual growth in Internet traffic. The key remaining link has been between the LAN and the WAN – the metropolitan area network (MAN).

Over the last year MANs have emerged as a critical and dynamically evolving arena within the overall network infrastructure. Not only are traffic demands rapidly escalating, the underlying network architectures, protocols and technologies are also experiencing sweeping change.

The emergence of Wavelength Division Multiplexing (WDM), the rise of higher speed optical connections and the drive toward voice and data convergence are all combining to put pressure on existing network architectures to keep up with the parallel explosions in both demand and capacity. In addition, the competitive landscape for MAN service providers is shifting, with the influx of whole new classes of carriers who do not necessarily carry the legacy baggage and inertia of previously deployed infrastructures, such as Synchronous Optical Network/ Synchronous Digital Hierarchy (SONET/SDH).

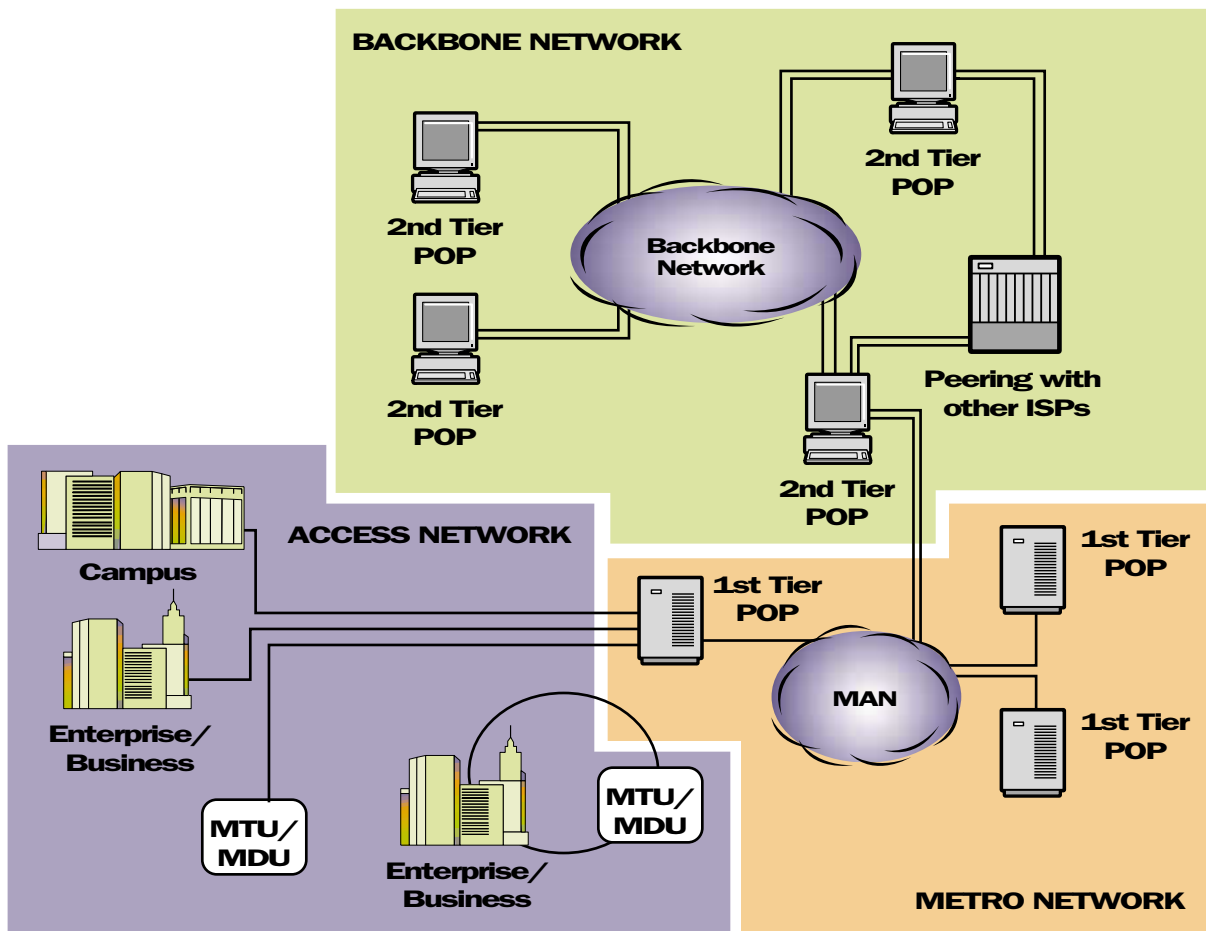

Traditionally, metropolitan communications infrastructures have been created and optimized to handle voice traffic, with data requirements arising as something of an afterthought.

Evolution of MAN Requirements

The concept of MANs is not new. They have been around since the early 1990s. In the early days, propriety time-division multiplexing (TDM) rings constituted MANs with optical amplifiers accomplishing the distance objectives. In the mid-1990s, ATM became the predominant technology to build MANs. The promise of ATM as the technology for converging data, voice and video was responsible for the unanimous decision. Most importantly the inherent capabilities in ATM to interleave itself into the SONET/SDH rings made it the prime choice. But a lot has happened since then – SONET/SDH infrastructures continue to be expensive to deploy and maintain, ATM has done little to enhance high-speed packet based connectivity and SONET/SDH-based bandwidth slicing is not effective to connect single users.

Escalating Data Traffic and Broadband Connectivity

Perhaps the most pervasive challenge in the MAN arena is the exponential increase in traffic being sent over networks. This is due in large part to the explosive growth of the Internet as a global information medium, used extensively by both individuals and businesses for research, commerce and entertainment.



In addition to the millions of new users who are going online every month, the nature of Internet applications are becoming more bandwidth intensive as the Internet has become an increasingly visual environment and multimedia content has become more widespread. For users, the emergence of broadband connectivity in the form of cable modems and DSL has also significantly widened the last mile of the network pipeline, giving them faster access and more propensity to make use of bandwidth-intensive content.

Convergence of Heterogeneous Services

Service convergence is another key factor driving the ongoing evolution of MANs. Traditionally, metropolitan communications infrastructures have been created and optimized to handle voice traffic, with data requirements arising as something of an afterthought.

From the copper-loop connections between users and their central offices to the uniform TDM infrastructures across the metro and wide area links, all aspects of the traditional communications structure were designed for connection-oriented voice rather than connectionless data traffic. Now, as data has become the dominant traffic type, a driving need has arisen for the seamless convergence of data, toll-quality voice and broadcast-quality video within a mutually optimized network.

Expansion of Raw Fiber Capacity

Another fact of life in the MAN marketplace has been a significant proliferation of raw fiber capacity. The availability of underutilized dark fiber is steadily increasing as municipalities, utilities and traditional telephone service providers routinely lay more fiber capacity than they can actually put into service. With the cost of the fiber itself representing a relatively small part of the total cost of putting the fiber in the ground, it is typically much cheaper to lay more fiber pairs in a single pass than to risk having to add more later.

In addition to traditional telephone companies, many other entities that already own metropolitan rights-of-way have also opted to invest in the installation of fiber cabling. For example, many municipalities and utilities have laid fiber along their existing right-of-way corridors to connect their own facilities and lease excess capacity to service providers and other corporate entities.

The WDM Capacity-Multiplier Effect

The evolution of Wavelength Division Multiplexing (WDM) is also dramatically increasing the carrying capacity of both MANs and WANs by multiplexing traffic onto individual wavelengths traveling on a common fiber. Current WDM capabilities support as many as 40 separate channels on a single fiber, while closer channel-spacing offers the potential to drive new WDM systems to 80 channels per fiber.

In addition to expanding available bandwidth, the migration of WDM into MANs pose significant additional challenges because the proliferation of wavelength channels must be efficiently and transparently managed to carry a variety of disparate traffic types for many different users.

Evolution of WDM	2000	<ul style="list-style-type: none">• 80+ Channels• 0.8 nm spacing• WDM, Integrated Systems with Network Management and add/drop functions
	1990s	<ul style="list-style-type: none">• 2 - 4 Channels• 3 - 5 nm spacing• Passive WDM Components/parts
	1980s	<ul style="list-style-type: none">• 2 Channels• Wideband WDM• 1310, 1550

The evolution of WDM is also dramatically increasing the carrying capacity of both MANs and WANs by multiplexing traffic onto individual wavelengths traveling on a common fiber.

Challenges and Opportunities for Service Providers

The changing face of the MAN landscape offers significant opportunities for competitive service providers who are not already locked-in to legacy infrastructures. Until recently, corporate customers have had to rely on traditional telecommunications service providers to move data across the MAN by leasing a T1, T3, OC3 or other defined circuit that is provisioned and maintained by the service provider. In most instances, this has involved long lead-times for provisioning the fixed circuits, high cost in traffic-based fees, plus the extra overhead required to convert Ethernet in the LAN to MAN transport protocols, such as ATM, SONET or Frame Relay – and back again.

With Ethernet now the de facto standard for LAN traffic, corporate customers prefer to seamlessly connect to the MAN using compatible native mode protocols instead of undergoing multiple conversions to and from ATM and SONET. In addition to significantly simplifying their network topologies, it also makes their corporate networks much more scalable and maintainable. Of course, for most corporations, the expense of acquiring rights-of-way and laying their own fiber optic cabling across metropolitan distances is cost-prohibitive and impractical.



An opportunity now looms for MAN service providers to meet these evolving customer needs by offering new networks with convergence-optimized data services based on 10 Gigabit Ethernet capabilities. By fortifying Gigabit Ethernet capabilities with targeted architectural enhancements, these new networks can provide the flexibility of native-compatible packet-based data flows along with the robust SONET-equivalent mechanisms needed for circuit protection, latency minimization and guaranteed bandwidth provisioning.

SONET Legacy Constraints

Within today's TDM voice-oriented networks, SONET technology has become widely deployed to provide high-capacity transport with the ability to scale up to gigabit per second rates. SONET/SDH self-healing rings enable service-level recovery within tens of milliseconds in the event of a failure. All of these features are backed up by well-established standards enabling a high degree of multivendor interoperability. However, with the paradigm shift from voice-optimized circuit-switched networks to data-optimized packet-switched networks, the SONET legacy infrastructure is now becoming constrained by its inherent limitations.

SONET Infrastructure: Made for Voice

SONET is basically a multiplexing technology, which means that it enforces a rigid TDM telecom hierarchy. This works well for all-voice traffic, as latencies and bandwidth are easily guaranteed by assigning a specific time-slice of bandwidth to each new connection. But it lacks the flexibility and smooth scalability required for data. In order to conform to the SONET infrastructure, carriers have to cram data streams into arbitrarily rigid channels. The slowest channel, VT-1.5, runs at 1.7 Mbps whereas the next higher increment, STS-1, jumps to 51.84 Mbps. Inherent inefficiencies are created because any unused capacity in each channel is wasted and, to make matters worse, these inefficiencies tend to become more pronounced as the ratio of data traffic on the network increases.

High Cost of Expansion and Lack of Smooth Scalability

Because of the high cost of SONET equipment, service providers face difficult challenges in scaling their MAN networks to accommodate the ongoing explosion in data traffic. The prospect of throwing more SONET cross-connects and add/drop multiplexers (ADMs) at rising traffic levels becomes prohibitively expensive, as can the requirement to terminate all individual WDM wavelengths with high-priced SONET equipment. New generation high-speed Ethernet switches offer an order-of-magnitude cost reduction.

Overhead Redundancy in the Protocol Stack

SONET is able to provide circuit protection and integrity by overlaying a set of TDM-based framing and transmission protocols onto the data link and network layers of the open systems interconnection (OSI) reference model. As mentioned above, this rigid framing structure works fine for voice but creates inefficiencies in the transport of non-uniform data traffic. The addition of another layer of overhead encapsulation – which is necessary for IP traffic – also consumes more of the network’s available carrying capacity.

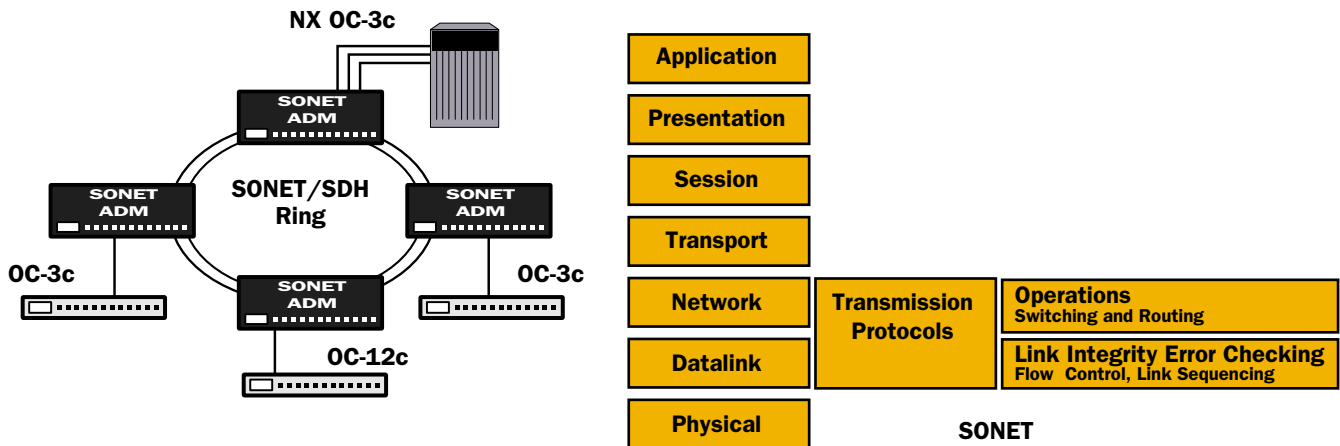

Some network system vendors have attempted to deal with data traffic by dividing the SONET capacity and statistically multiplexing ATM or IP into one part, or by using SONET framing to encapsulate and send data over WDM wavelengths. While these adaptations provide a better focus on data traffic, they do little or nothing to reduce SONET’s inherent overhead and cost.

Long Provisioning Cycles and Inflexible Billing Mechanisms

Among the key limitations that put SONET-based service providers at a competitive disadvantage are the inherently long time-cycles and lack of flexibility involved with provisioning SONET connections for customers. Because SONET was originally designed to efficiently carry uniform voice traffic, it doesn’t include the flexible billing and management features that carriers need in order to offer value-added services like virtual private networks (VPNs), web hosting, co-location or application outsourcing. Providing connectivity does very little for the service provider’s bottom line. It is the ability to offer tiered services that maximizes profit. Without these features, service providers who are tied to SONET legacy infrastructures have no built-in mechanisms to quickly recoup their investments in network upgrades to support the explosion of data requirements.

Overhead Redundancy in the Protocol Stack

SONET is able to provide circuit protection and integrity by overlaying a set of TDM-based framing and transmission protocols onto the data link and network layers of the open systems interconnection (OSI) reference model. As mentioned above, this rigid framing structure works fine for voice but creates inefficiencies in the transport of non-uniform data traffic. The addition of another layer of overhead encapsulation – which is necessary for IP traffic – also consumes more of the network’s available carrying capacity.

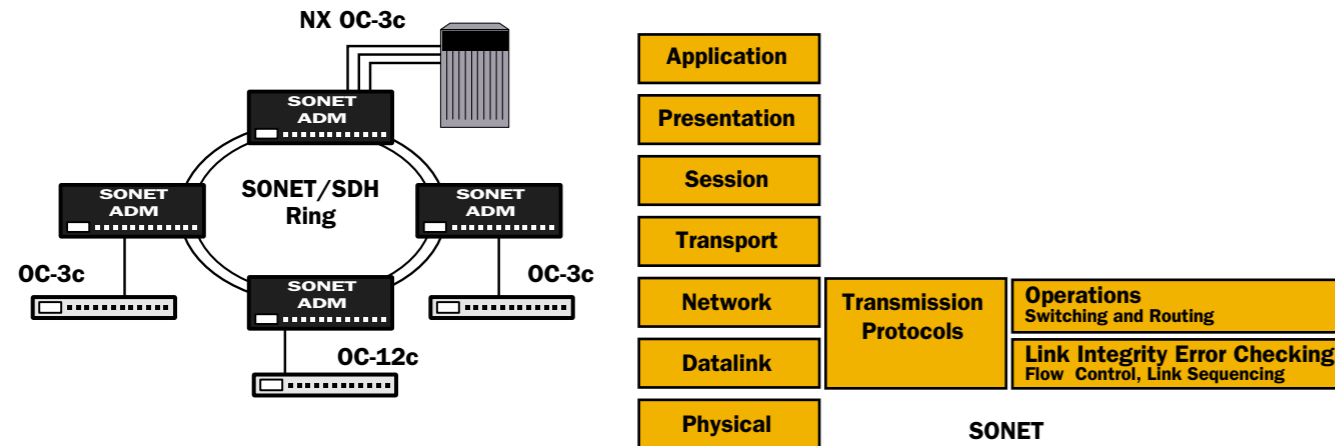

Some network system vendors have attempted to deal with data traffic by dividing the SONET capacity and statistically multiplexing ATM or IP into one part, or by using SONET framing to encapsulate and send data over WDM wavelengths. While these adaptations provide a better focus on data traffic, they do little or nothing to reduce SONET’s inherent overhead and cost.

Long Provisioning Cycles and Inflexible Billing Mechanisms

Among the key limitations that put SONET-based service providers at a competitive disadvantage are the inherently long time-cycles and lack of flexibility involved with provisioning SONET connections for customers. Because SONET was originally designed to efficiently carry uniform voice traffic, it doesn’t include the flexible billing and management features that carriers need in order to offer value-added services like virtual private networks (VPNs), web hosting, co-location or application outsourcing. Providing connectivity does very little for the service provider’s bottom line. It is the ability to offer tiered services that maximizes profit. Without these features, service providers who are tied to SONET legacy infrastructures have no built-in mechanisms to quickly recoup their investments in network upgrades to support the explosion of data requirements.

The New MAN: Recipe for Success

The key issues facing large-scale IP service providers and small competitive access providers are building networks that are robust and deliver high performance connectivity. While MAN data solutions used to rely on SONET/SDH-based transport with either point-to-point or ring architectures, it is clear that those approaches were sub-optimal – both from an economic and functionality perspective.

Service providers are becoming more and more open to alternate approaches. But while they seek the functionality that will move them forward, they still want to be able to keep a few values that SONET/SDH offered, including the ability to offer toll-quality voice and broadcast-quality video services.

MAN Wish List

The following requirements are becoming the common list from all service providers, big and small. These requirements are unique inside the layers of hierarchy of a typical MAN:

Core Rings

1. **Rock solid network architecture:** One that imitates the dual counter-rotating circuit protection capability of SONET/SDH. With IP comes Layer 3 intelligence. And service providers desire a robust and fast Layer 3 convergence mechanism in addition to passive optical failover if a service disruption or fiber infrastructure failure occurs.
2. **Exhaustive list of features:** In addition to the speeds and feeds that make MANs happen, service providers want to pay special attention to the ability to offer tiered services. These services involve traffic classification/segregation on a per-user or per-flow basis, as well as incorporate usage-based billing, policing and authentication capabilities.
3. **Greater flexibility:** The first and foremost need is for interoperability with existing equipment at all locations – the central office (CO), point of presence (POP) and the customer premises (CP). In addition, the ability to deliver “bandwidth by the slice” enables service providers to offer competitive and custom services tailored to meet market demands.
4. **Cost:** Lastly, the expectation is a cost model that is less than SONET/SDH. This is not limited to equipment acquisition costs only, but also includes the cost involved in initial deployment and day to day maintenance. The cost involved in collecting data to ensure head-room in the network, the raw bits and bytes that turn into billable services and provisioning is where SONET/SDH has had the biggest negative impact on the service provider’s business plan.

Access Rings

1. **Rapid and effective provisioning:** The service provider's business plan typically involves offering data-only services as well as data/voice or data/voice/video services. On the raw bandwidth side, the goal is to offer 1 Mbps through 10 Mbps in simple increments that are soft configurable on the fly from a centralized management station.
2. **Quality of service (QoS):** Viewed as the only tool available to offer tiered services and rightfully so. QoS also extends itself to per user- or per flow-based bandwidth allocation.
3. **ISP flexibility:** From an access MAN perspective, it is of tremendous importance to be able to connect to at least two separate Internet service provider (ISP) networks. This not only ensures an alternate path for redundancy and optimum response times but also enable the customer to pick lower priced services for non business-critical traffic.
4. **Billing:** The most important of them all, the ability to offer and bill for varying levels of service that include per user billing, flat rates, always-on service and even customized scenarios that combine flat rates and an overage fee at a separate rate.

Creating a New Convergence-Optimized Architecture

Core Objectives

In response to service provider requirements for improved network infrastructures that are more flexible, scalable and responsive to customers requirements, a new architectural paradigm is emerging. Designed from the ground up, this convergence-optimized architecture combines the best features of SONET/SDH, such as guaranteed latency and reliability, with the unmatched data capacity, scalability and low cost of Ethernet networks.

Additionally, all the real world issues and challenges have been overcome in the equipment available for deployment today – tiered services, per user billing, path protection, rate limiting and more.

Provisioning Gigabit Ethernet Over WDM in the MAN

At the heart of the new network architecture is the direct provisioning of multiple Gigabit Ethernet channels over WDM fiber to create a scalable robust data-optimized optical ring. As a natural extension to Gigabit Ethernet, 10 Gigabit Ethernet also provides an inherently scalable mechanism to efficiently and flexibly aggregate native data traffic across high-speed optical MANs. By eliminating SONET's overhead, but preserving SONET-like protection and latency management benefits into Ethernet, the new MAN architecture provides an optimized infrastructure for data, toll-quality voice and broadcast-quality video.

Not only does the direct provisioning of Ethernet over WDM eliminate overhead, it reduces equipment costs and provides a network architecture that scales smoothly. While customer premises equipment remains Ethernet, extending Ethernet technology throughout the MAN offers smoother integration, better performance and seamless management.

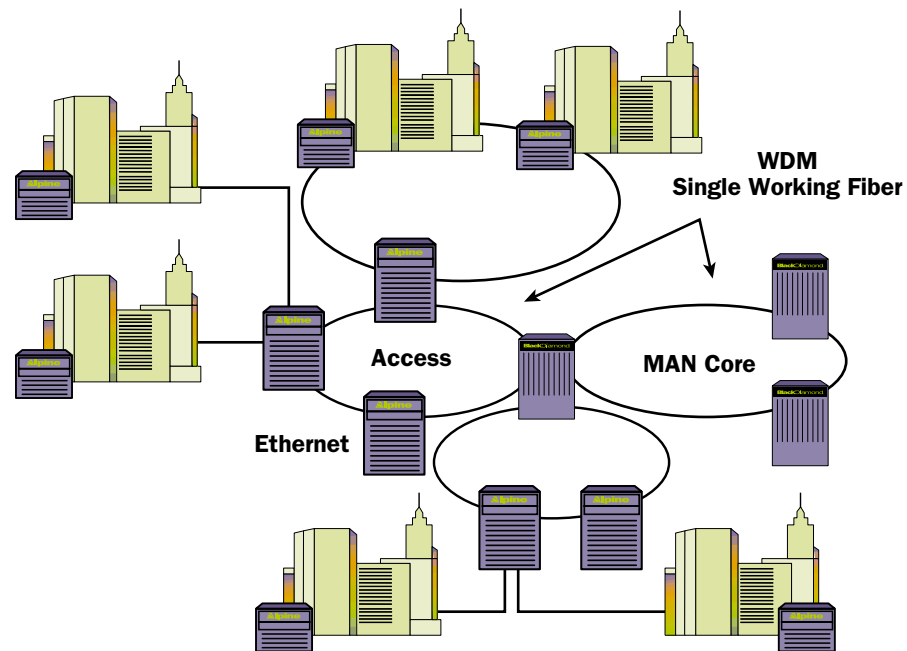

Integrating WDM directly into IP chassis switches boosts capacity, simplifies network deployment and management, and reduces support costs. For example, a converged-switch in the new architecture can collapse into a single system all of the functionality that required a WDM multiplexer, SONET ADM and ATM switch under the old SONET paradigm.

In addition, by not imposing arbitrary framing structures, the new convergence-optimized network architecture allows the flexible allocation of bandwidth by the wavelength and more efficient utilization of all available bandwidth. Besides creating more efficiency and flexibility across the MAN, the direct deployment of Ethernet in the WDM transport infrastructure also greatly enhances the carrier's ability to extend broadband connectivity over the last mile to customers. Because the new data-optimized optical MAN infrastructure supports the 10/100/1000 Ethernet data traffic that is predominant in LANs, the aggregation of user traffic on to the MAN is a much more straightforward proposition.

IP TDM: Deterministic Latency for Voice Traffic

One of the keys to the new architecture is the innovative use of an IP TDM model, which provides sophisticated traffic shaping and bandwidth management capabilities to ensure deterministic latency for voice traffic. IP TDM allows circuit emulation on an as-needed basis, which guarantees a transit path with fixed-latency characteristics to support voice or video transmissions. Until recently, conventional wisdom assumed that only ATM could provide the fixed-latency data paths required to support voice. However, experience has now demonstrated that gigabit-level IP switches interfaced directly to the optical WDM network can be designed with traffic prioritization schemes that provide SONET-equivalent voice capabilities along with all the advantages of flexible data handling.

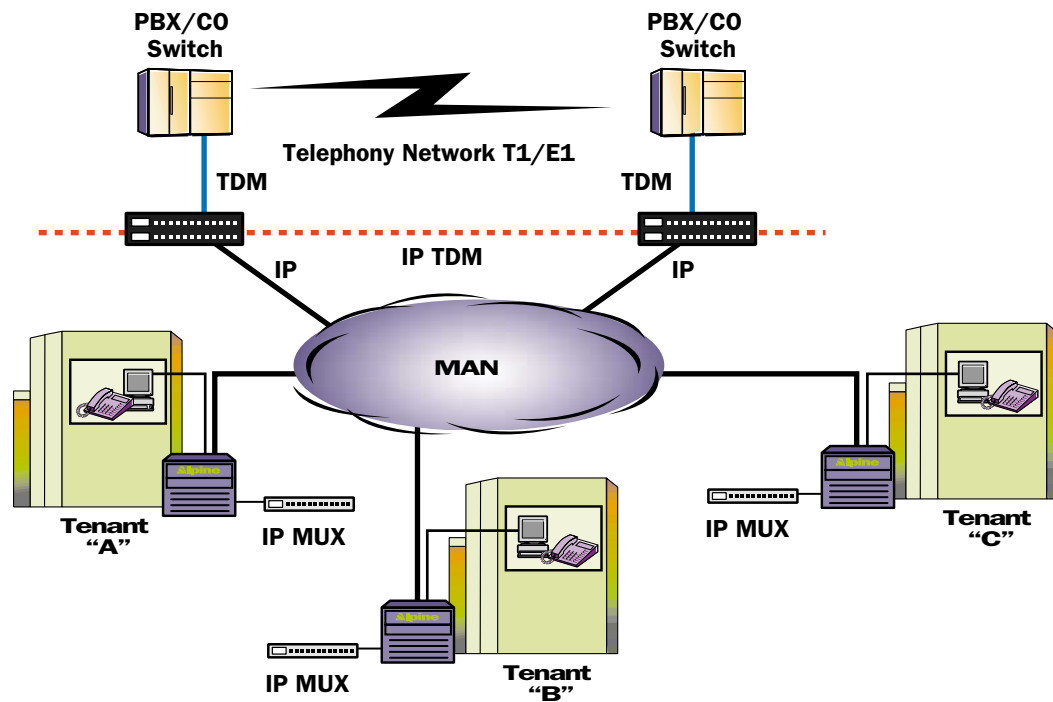

Delivering toll-quality voice services over a Gigabit Ethernet MAN.

The ability to connect the IP MAN to the existing PBX via trunked E1/T1 connections protects the investment in voice equipment. Smaller IP PBX equipment is also available today with multiple POTS (Plain Ordinary Telephone Service) ports to direct telephone connectivity.

Flexible Provisioning of Rate-Limited Pipes

In contrast to the rigidity of SONET infrastructures, the inherent flexibility of these new convergence-optimized networks allows for dynamic provisioning of bidirectional rate-limited pipes – for both inbound and outbound traffic. This enables carriers to tailor service offerings to specific customer requirements, regardless of the size of the physical pipe. As an example, through Policy-Based Quality

of Service, the available bandwidth of a rate-limited pipe could easily be set to correspond to an OC-3 equivalent TDM circuit in SONET. Then, as the customer's requirements change, the rate-limited pipe could be dynamically upgraded in software to quickly provide an OC-12 or OC-48 equivalent, whereas in a traditional SONET network the re-provisioning process typically entails a long, expensive and hardware-intensive physical process.

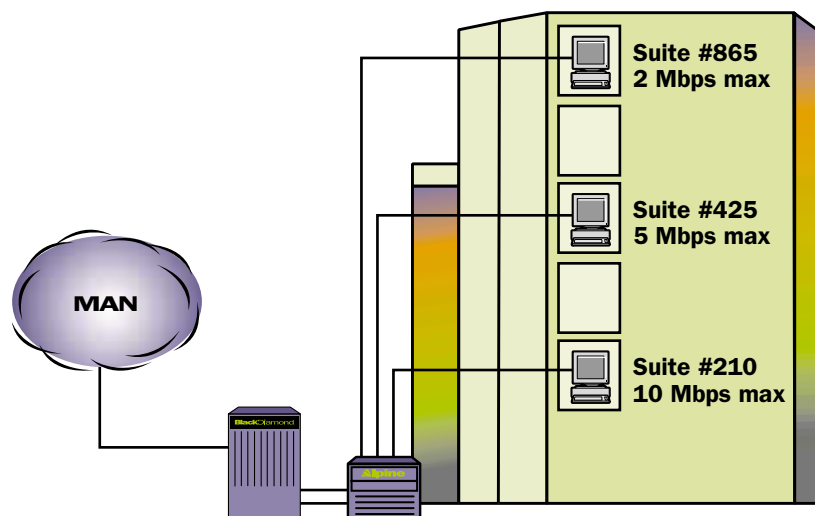

When customer traffic includes data and voice, the network has to be able to rate-limit delay-insensitive data traffic to allow voice traffic to go through smoothly while still policing the customer traffic to the signed-up level.

The immediate advantage of this bidirectional rate limiting capability is the ability to enforce policies and/or ensure the availability of bandwidth for delay sensitive traffic.

Policy enforcement is an essential complement to offering tiered services. Depending on needs, a particular customer can sign up for a certain level of service, such as 500 Kbps of traffic/bandwidth. Utilizing the rate-limiting capability, service providers are able to police incoming traffic from that customer to ensure compliance to the level of service for which they signed-up. At the first-tier aggregation point, typically a POP location, rate limiting is critical to optimizing network bandwidth engineering.

Rate limiting is also key to successfully offering a true multiservice network. Delay-sensitive applications like voice over IP (VoIP) or packetized voice (TDM over IP) need to be handled differently than data to ensure lower latency and delay variance. When customer traffic includes data and voice, the network has to be able to rate-limit delay-insensitive data traffic to allow voice traffic to go through smoothly while still policing the customer traffic to the signed-up level.

Integrated Circuit Protection

The new convergence-optimized architecture is also designed to provide integrated circuit protection at levels that SONET users have come to depend upon. SONET typically makes use of the second fiber pair in a counter-rotating ring in order to provide circuit protection within milliseconds of a failure. In contrast, the new optical MAN architecture makes use of the full bandwidth on both fiber pairs while simultaneously building circuit protection mechanisms within the Gigabit Ethernet infrastructure. Today, there is support for up to four bidirectional Gigabit Ethernet channels in a single strand of fiber. At locations where a full fiber pair is available this equates to eight bidirectional Gigabit Ethernet channels. The bidirectional nature of traffic flows allows service providers to build rings with just a single fiber strand.

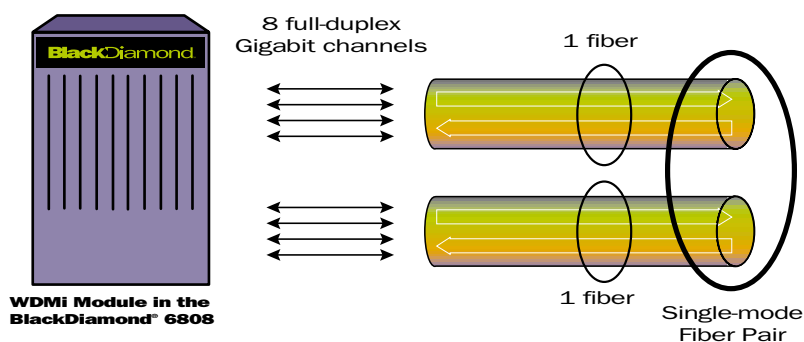

WDM channels inside single-mode fiber strands facilitate both ring and point-to-point connectivity.

In addition, Multi-Protocol Label Switching (MPLS) provides the built-in ability to pre-establish multiple protected paths within the optical ring, thereby enabling immediate switching to alternative circuit routes. Transparent fast-conversion algorithms implemented within well-controlled optical-ring infrastructures can achieve 50-millisecond failure recovery. The bottom line is that all of the fiber bandwidth is utilized on an ongoing basis while also providing optimized failure recovery paths.

Usage-Based Billing

The mission-critical status of the customer's network is fully dependent upon the fault tolerance and redundancy built into the service provider infrastructure. The easiest way for customers to achieve business objectives is to set up a service-level agreement (SLA) with their service provider. To deliver on the SLA, the service provider must rely on the network's ability to offer tiered services.

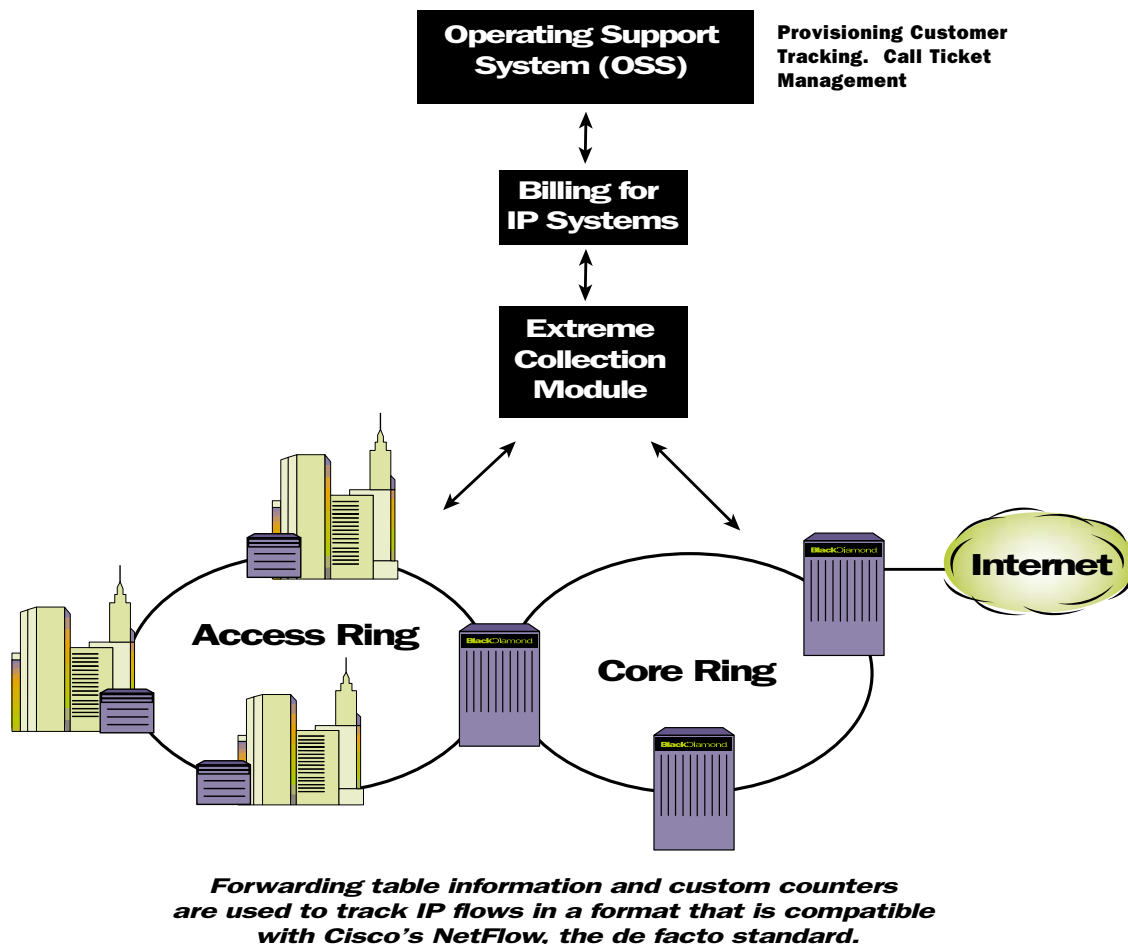

The ability to perform usage-based billing on the part of the new convergence-optimized Gigabit Ethernet MAN closes the loop on the business aspects of this service offering. In addition to SNMP, MIB II and RMON statistics the switching equipment that form the MAN infrastructure must have built-in configurable counters on a per-port basis.

Additional granularity is provided within the port for configurable counters on a per-queue basis. It is typical to expect up to eight queues per port. These counters allow service providers to track virtually any data or statistical information – overall usage, aggregate traffic to and from specific addresses, traffic flows as source and destination pairs, traffic generated by individual applications, TCP or UDP socket information, and more. This data is then translated into billable records. State-of-the-art billing systems from renowned vendors in the industry rely on this type of data collection.

Additionally, the ability to support traffic mirroring in the switch should not be overlooked. This capability can be used in conjunction with external probes to collect data and translate it into billable records.

Virtual Metropolitan Area Networks (vMANs™)

Contrary to popular belief there is still a considerable presence of legacy protocols within the customer's LAN. Service providers have had to pay special attention to handle the unique characteristics of these legacy protocols when offering simple Layer 2 transparent LAN services over their MANs. The innovative virtual MAN (vMAN) technology available with convergence-optimized Ethernet MANs overcomes the challenges by appending the packets with two separate tags – one for the customer domain and the other for the service provider domain.

This dual domain feature also come in handy when offering virtual private network (VPN) services and allowing the customer to switch their ISPs without disrupting services.

The overall benefit to the service provider is tools to offer the custom services that customers are demanding without a network deployment and management nightmare.

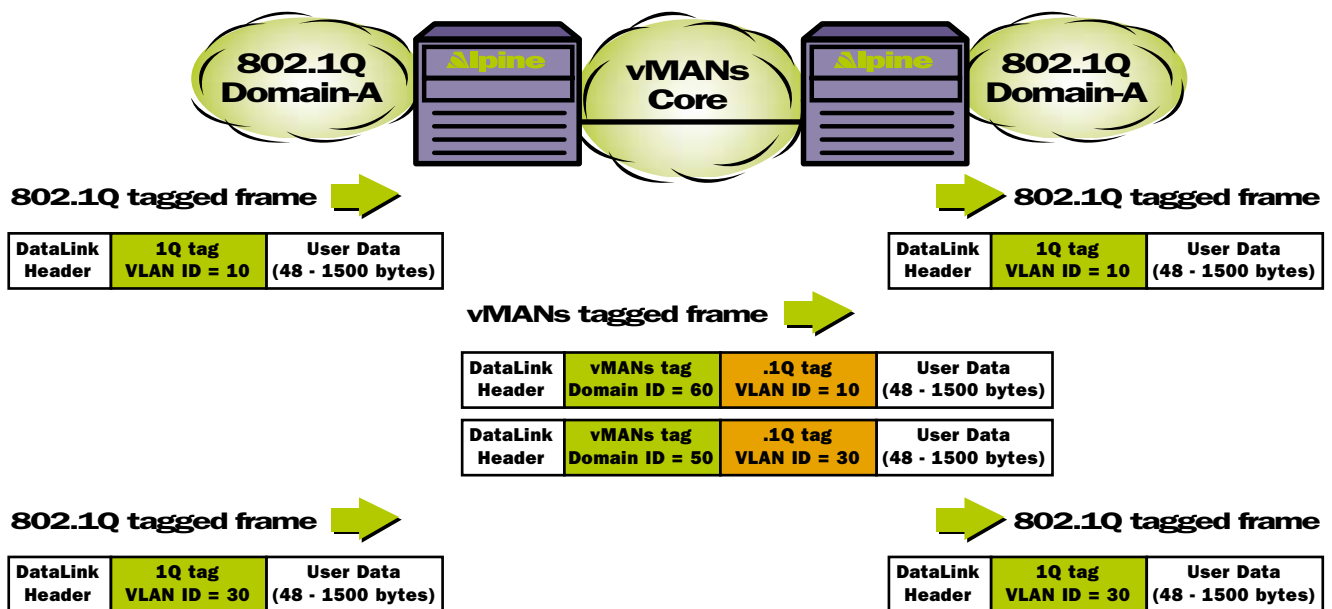

vMAN packet encapsulation for Metropolitan Area Networks.

Real-World Benefits and Advantages

Seamless Coverygency of Services

New convergence-optimized MANs allow service providers to seamlessly tailor their offerings to address the full range of real-world customer requirements by breaking out of the rigid limitations of the traditional SONET network model. Service providers can leverage the new optical MAN and its IP compatibility with existing Ethernet LANs to provide no-hassle customer interconnections directly to the MAN infrastructure, regardless of the traffic type.

Predictable Quality of Service Performance Levels

Sophisticated traffic prioritization, queuing and rate-limiting mechanisms built into the core architecture, from the ASIC level upwards, give service providers the flexibility to allocate bandwidth to customers on a per-slice basis, while simultaneously enforcing tight guarantees on latency levels for special traffic classes, such as voice and video.

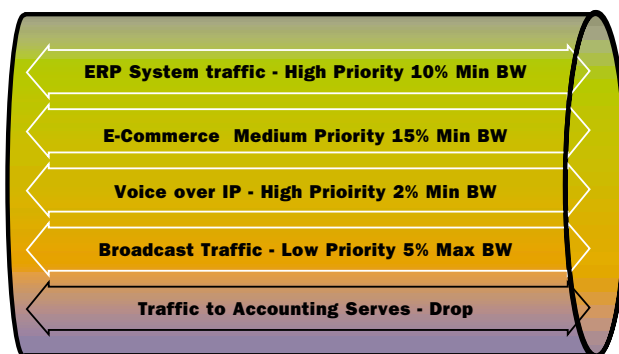

Sophisticated traffic prioritization, queuing and rate-limiting mechanisms built into the core architecture, from the ASIC level upwards, give service providers the flexibility to allocate bandwidth to customers on a per-slice basis,

Rapid and Incremental Provisioning of Services

In contrast to complex and expensive configuration changes that are required to provision services or change circuit capacities in the traditional SONET world, services on the new data-optimized optical MAN can be provisioned or changed via software, in a matter of minutes rather than taking weeks or months. As a result, customers become attuned to requesting and using more services as they actually require them, rather than holding off because of high incremental expenses or long lead times. For the service provider, the bottom line is better responsiveness to customer needs, increased revenues and an overall enhanced competitive position.

Inherent Scalability and Extensibility

From an infrastructure investment standpoint, these new optical MAN architectures provide smooth scalability across the full range of user requirements. This allows carriers to provide capacities as high as 10 Gigabit Ethernet, as well as the flexibility to provision individual data links down to rate-limited bandwidths as small as 500 Kbps. In addition, by breaking with the legacy constraints of the past, these new networks provide a solid foundation for future extensibility through coming innovations such as multiprotocol lambda switching of individual wavelength data streams.

In the final analysis, the deployment of new convergence-optimized optical networks is enabling MAN service providers to step beyond the limitations of current SONET infrastructures, while carrying forward the key SONET benefits of guaranteed circuit protection and latency management. At the same time, the direct deployment of multi Gigabit Ethernet capabilities over WDM-enhanced optical rings has opened the door for carriers to deliver unprecedented levels of performance, flexibility and responsiveness to their end customers.

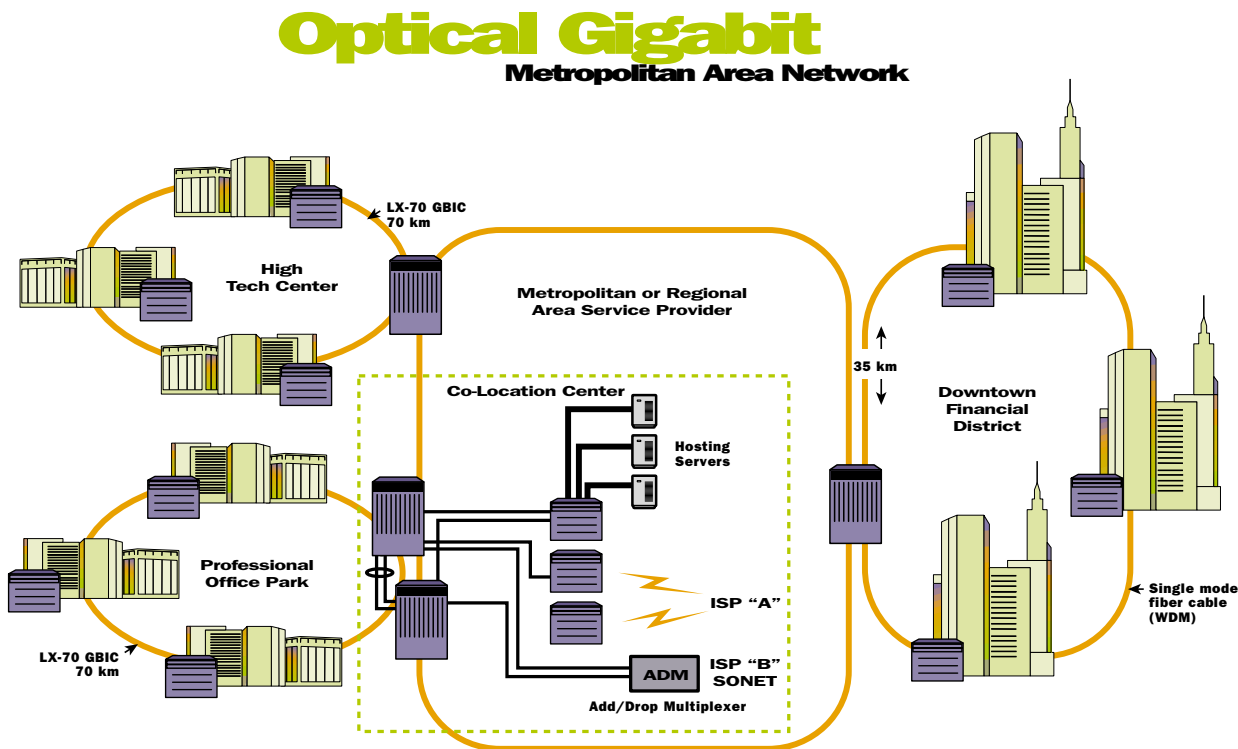



3585 Monroe Street Santa Clara, CA 95051-1450 Phone 408.579.2800 Fax 408.579.3000
Email info@extremenetworks.com Web www.extremenetworks.com

© 2000 Extreme Networks, Inc. All rights reserved. Extreme Networks and BlackDiamond are registered trademarks of Extreme Networks, Inc. in certain jurisdictions. Alpine, ExtremeWare, ExtremeWare Vista, ExtremeWorks, ExtremeAssist, ExtremeAssist1, ExtremeAssist2, PartnerAssist, Extreme Standby Router Protocol, ESRP, IP TDM, SmartRedundancy, SmartTraps, Summit, Summit1, Summit4, Summit4/FX, Summit7i, Summit24, Summit48, Summit Virtual Chassis, SummitLink, SummitGbX, SummitRPS, Velocity, vMAN, the BlackDiamond logo and the Extreme Networks logo are trademarks of Extreme Networks, Inc., which may be registered or pending registration in certain jurisdictions. The Extreme Turbodriven logo is a service mark of Extreme Networks, Inc., which may be registered or pending registration in certain jurisdictions. All other registered trademarks, trademarks and service marks are property of their respective owners. Specifications are subject to change without notice.